

# User's Manual

**Hulkkuffs** professional handcuffs.

## Warning

1. **Hulkkuffs** are designed for trained professionals.
2. **Hulkkuffs** are manufactured using high-precision machining, <0.1mm or 4/1000 inch in tolerance. ---  
----- Disassembling and reassembling are **not recommended**.
3. Lubrication has been made in factory; **no lubrication** required in daily operations.
4. Customer lubrication is **not recommended**, **incorrect lubs** catch dirt and debris and may block the parts from moving properly or freely.

## Before Operation

5. Make sure you have the special keys **reachable**, it is very hard to remove with other keys,
6. **Regularly** test with your fingers (monthly, or after each usage will be ok), make sure all parts move freely,
7. You have authorization to cuff the individual, or the individual consent to be handcuffed,
8. Get to know local laws: handcuffs are strictly restricted in certain regions or countries.

## Never

9. Never apply **Hulkkuffs** on kids' or minors', very small wrist **may not** activate the overtightening prevention mechanism properly.
10. Never operate the **Hulkkuffs** when impaired, at high up, in water, or in driving.

## Maintenance

- 1, Always remove dirt and debris.
- 2, Wipe with dry, soft, **dust free** fabric.
- 3, Disinfect/Sanitize after use, using only **70% IPA** (Isopropyl Alcohol).
- 4, Never use types of solvent or detergent other than IPA 70%.
- 5, Check all functions regularly. (Monthly, or weekly, or after each usage is recommended).

## Lifetime Guarantee

- 1, All Hulkkuffs handcuffs are lifetime guaranteed: a bonus manufacturer extension from standard distributors and retailers' warranty.
- 2, Free exchange for manufacturing defects, (purchase proof required).
- 3, Free exchange for a latest version, even if there is no defect, **after 20 years from purchase**, (purchase proof required).
- 4, Shipping cost will be applied in case 2 and 3.

**Hulkkuffs** handcuffs are tested with standards higher than the NJI.

	<b>NJI standard</b>	<b>Hulkkuffs standard</b>	<b>Remarks</b>
1, Salt Spray Corrosion Resistance	Assembled handcuffs. salt spray for <b>12 hours.</b>	All parts before assembling. salt spray for <b>24 hours.</b>	
2, Cheek Plate Tamper Resistance	23.0 N-M 204 lbf /in	23.0 N-M 204 lbf /in	
3, Tensile Testing, Locking Mechanism.	Double lock each handcuff with the ratchet engaged <b>at the first notch.</b> a tensile force of 2200 N (495 lbf)	Lock each handcuff with the ratchet engaged <b>at the Second notch.</b> a tensile force of 2200 N (495 lbf)	the second notch is the first active lock notch
3, Overtighten mechanism	N/A	10,000 cycles test. No failure. applied force=70 lbf.	
4, Locking Mechanism, life cycles	N/A	30,000 cycles tested. No failure.	
5, Shimming-proof and picking-proof test	N/A	60 minutes with a paperclip or bobby pin, or universal handcuff key	

What is new in **2026 B** editions. (in comparison to 2025 editions).

- 1, Improved overtightening-proof systems, covers smaller sized wrists.
- 2, Modified mechanisms, greatly reduce failure rates in snow, dirt and rain.
- 3, Robotically assembled, reduced cost.
- 4, Improved surface: IPA 70% safe for regularly disinfection.

2025 models (A editions, materials: 7075 and 6061)

<p>Type A1, Aviation Aluminum, 7075-T6. Hinged, Glossy nature.</p>	<p>Type A2, Aviation Aluminum, 7075-T6. Chained, Glossy nature.</p>	<p>Type A3, Aluminum Alloy, 6061-T6. Hinged, Matte.</p>	<p>Type A4, Aluminum Alloy, 6061-T6. Chained, Matte.</p>

2026 models (B editions, material: 7075 aviation aluminum only)

With three colors available: **Blue, Orange and Grey.**

<p>Type B1, Aviation Aluminum, 7075-T6. Hinged, Glossy nature. Blue, Orange and Grey</p>	<p>Type B2, Aviation Aluminum, 7075-T6. Chained, Glossy nature. Blue, Orange and Grey</p>	<p>Type B3, Aviation Aluminum, 7075-T6. Hinged, Matte. Blue, Orange and Grey</p>	<p>Type B4, Aviation Aluminum, 7075-T6. Chained, Matte. Blue, Orange and Grey</p>

**Apertures: no changes.**

Maximum aperture, diameter	80mm	3.15in
Minimum aperture, diameter	45mm	1.77in
Maximum aperture, perimeter	251mm	9.9in
Minimum aperture, perimeter	141mm	5.6in

**Net weight (include two keys): 11g increased.**

A1 hinged	265g	0.58 lb	9.4 oz
A2 chained	245g	0.54 lb	8.6 oz
A3 hinged	260g	0.57 lb	9.2 oz
A4 chained	240g	0.53 lb	8.4 oz

B1 hinged	276g	0.62 lb	9.7 oz
B2 chained	256g	0.58 lb	8.9 oz
B3 hinged	276g	0.62 lb	9.7 oz
B4 chained	256g	0.58 lb	8.9 oz

**Specifications subject to change without notice.**

Anatomy of Hulkkuffs

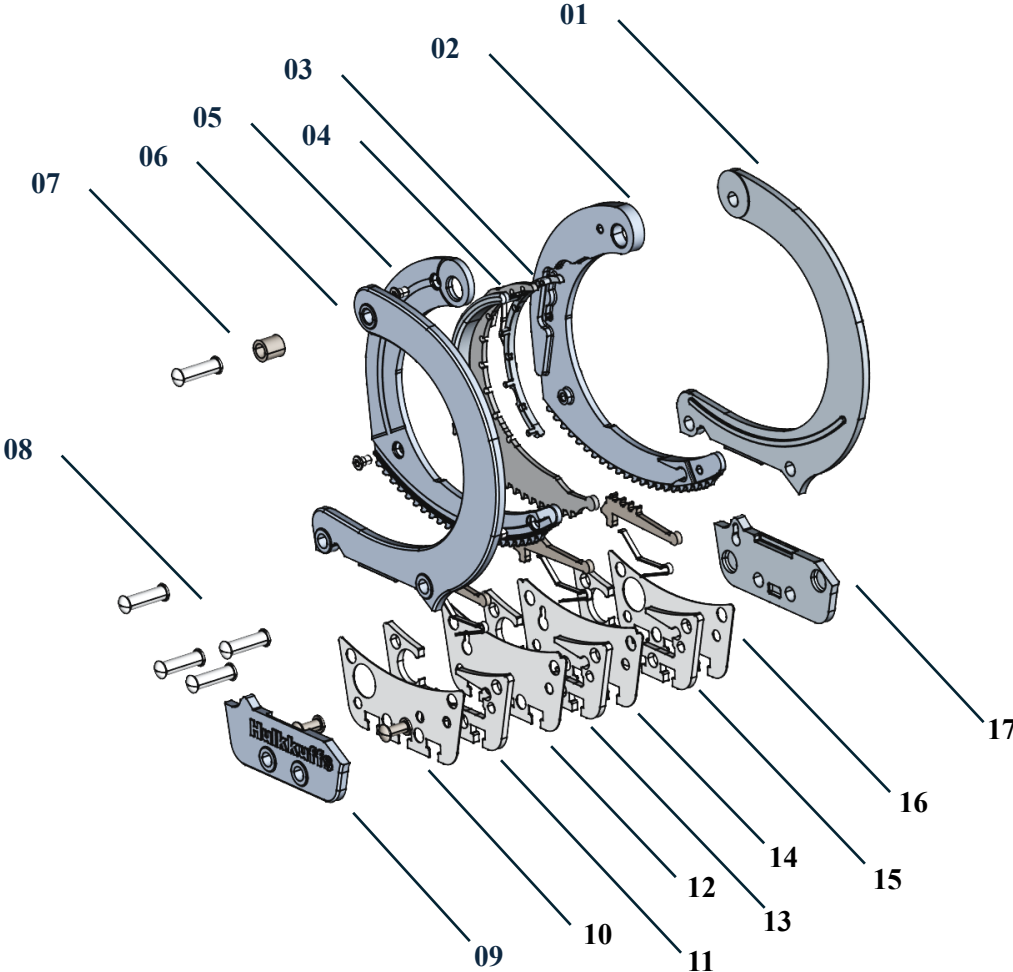

## Anatomy of a Single Cuff

Each individual cuff is composed of several components:

01, **Double Strand** (Body) A: The fixed part of the cuff that houses all the internal locking mechanisms. It provides the track through which the single strand passes.

02, **Single Strand** (Bow) A: The first mobile, curved arm of the handcuff that pivots 360 degrees around a Strand Rivet (or axis pin). It features fixed teeth along its outer edge.

03, **Middle ratchet**: The mobile part of the tension control mechanism, which is housed in between two single strands (bow A and bow B), and rotates around its small end. It provides the automatically locking function when pushed from inner side and engaged with the middle stop pawl located in the pawl holder assemble (13).

04, **Extended wings** of the middle ratchet 3, which provide an enlarged contacting surface to reduce pressures on wrist.

05, **Single Strand** (Bow) B: The second mobile, curved arm of the handcuff that pivots 360 degrees around a Strand Rivet (or axis pin). It features fixed teeth along its outer edge.

06, **Double Strand** (Body) B: The fixed part of the cuff that houses all the internal locking mechanisms. It provides the track through which the single strand passes.

07, Rivet and rotation axis sleeve.

08, Rivets.

09, Blind Face.

10, 12, 14, 16. **Spacer and Separators**: used to isolate three independent pawls and holders from interfacing each other.

11, The **Pawl A** (paired with bow A): a spring-loaded, pivoted bar located inside the body. It contains teeth that engage with the teeth of the single strand to allow it to move in only one direction (closing or tightening).

13, The **Middle Pawl** (paired with the middle ratchet): a spring-loaded, pivoted bar located inside the body. It contains teeth that engage with the teeth of the middle ratchet to stop further tightening of the bows when pushed from inner side, it always allows the middle ratchet to move in opening or loosening directions.

15, The **Pawl B** (paired with bow B): a spring-loaded, pivoted bar located inside the body. It contains teeth that engage with the teeth of the single strand to allow it to move in only one direction (closing or tightening).

17, **Keyhole Face**: Located on the side of the body, used to insert the handcuff key to retract the pawls to release the ratchets. A serial number and QR code are on the Keyhole Face.

### 11, 13, 15, **Triple Lock Mechanisms:**

Two independent locks 5/11 and 2/15 prevent the bows from opening or loosening.

One independent lock 3/13 prevent bows from further tightening when pushed from inner side.

### Types of Connection Linkages

The two cuffs are joined by one of four primary methods, which dictate how much mobility the subject retains:

**Chain Cuffs:** The most common variety, where cuffs are linked by a short, 2-inch chain with swivels at each end to prevent the chain from binding.

**Hinged Cuffs:** Cuffs are joined by a metal hinge, limiting movement to a single axis. This provides more control than chains but is more restrictive.

### **Technical Standards.**

Standard metallic handcuffs used by agencies like the Royal Canadian Mounted Police or US departments typically follow NIJ Standards, which require:

Weight: No more than 15 oz (425 g).

Strength: Must withstand a tensile force of 495 lbf (2200 N) for 30 seconds.

Durability: Resistant to salt spray corrosion and tampering.

At least 30,000 cycles for the handcuff,

10,000 cycles for the overtightening-proof mechanism.

**Specifications subject to change without notice.**